

OWNER'S GUIDE

• ASSEMBLY • OPERATION • MAINTENANCE • PARTS •

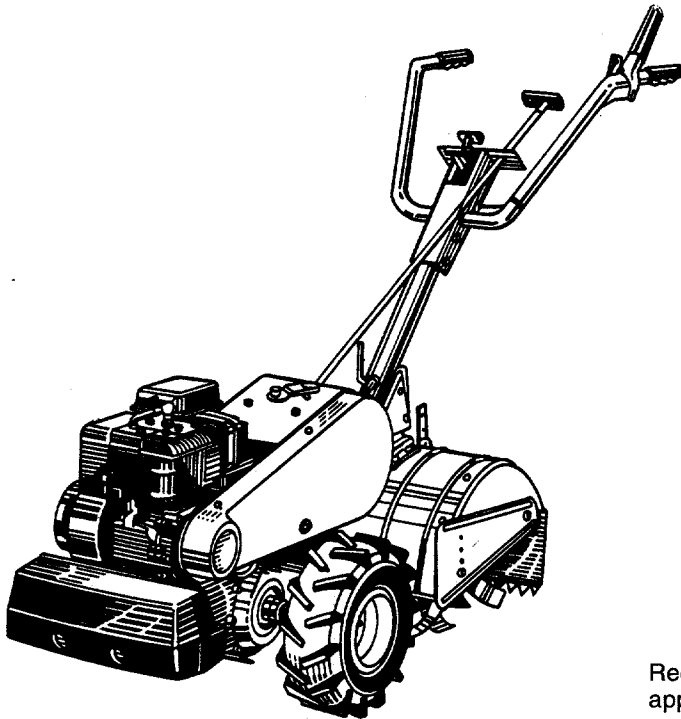

REAR TINE TILLER

Model Number
213-430-000

IMPORTANT!

Record the **Model No.** and **Mfg. Code** which appear on your unit in the space below. You **must** have these numbers, along with the date of purchase, in order to receive warranty or service.

MEETS ANSI SAFETY STANDARDS

MODEL NO.

MFG. CODE

**Important:
Read Safety Rules
and Instructions Carefully**



Made
in
AMERICA

WARNING: This unit is equipped with an internal combustion engine and should not be used on or near any unimproved forest-covered, brush-covered or grass-covered land unless the engine's exhaust system is equipped with a spark arrester meeting applicable local or state laws (if any). If a spark arrester is used, it should be maintained in effective working order by the operator.

In the State of California the above is required by law (Section 4442 of the California Public Resources Code). Other states may have similar laws. Federal laws apply on federal lands. A spark arrester for the muffler is available through your nearest engine authorized service dealer or contact the service department, P.O. Box 368022, Cleveland, Ohio 44136-9722.

INDEX

Rules for Safe Operation	2	Lubrication	11
Assembly	3	Maintenance	11
Controls	9	Off-Season Storage	12
Operation	9	Trouble Shooting Guide	13
How To Use Your Tiller	10	Illustrated Parts and Parts Lists	14-18
Adjustments	11		

IMPORTANT

RULES FOR SAFE OPERATION



THIS SYMBOL POINTS OUT IMPORTANT SAFETY INSTRUCTIONS WHICH, IF NOT FOLLOWED, COULD ENDANGER THE PERSONAL SAFETY AND/OR PROPERTY OF YOURSELF AND OTHERS. READ AND FOLLOW ALL INSTRUCTIONS IN THIS MANUAL BEFORE ATTEMPTING TO OPERATE YOUR TILLER. FAILURE TO COMPLY WITH THESE INSTRUCTIONS MAY RESULT IN PERSONAL INJURY. WHEN YOU SEE THIS SYMBOL—  **HEED ITS WARNING.**



DANGER: Your tiller was built to be operated according to the rules for safe operation in this manual. As with any type of power equipment, carelessness or error on the part of the operator can result in serious injury. If you violate any of these rules, you may cause serious injury to yourself or others.

1. It is suggested that this manual be read in its entirety before attempting to assemble or operate this unit. Keep this manual in a safe place for future and regular reference and for ordering replacement parts.
2. Your tiller is a precision piece of power equipment, not a plaything. Therefore, exercise extreme caution at all times.
3. Read this owner's manual carefully. Be thoroughly familiar with the controls and the proper use of the equipment.
4. Never allow children to operate a power tiller. Only persons well acquainted with these rules of safe operation should be allowed to use your tiller.
5. No one should operate this unit while intoxicated or while taking medication that impairs the senses or reactions.
6. Keep the area of operation clear of all persons, particularly small children and pets.
7. Do not operate equipment when barefoot or wearing open sandals. Always wear substantial footwear.
8. Do not wear loose fitting clothing that could get caught on the tiller.
9. Do not start the engine unless the shift lever is in the neutral (N) position.
10. Do not stand in front of the tiller while starting the engine.
11. Do not place feet and hands on or near the tines when starting the engine or while the engine is running.
12. Never attempt to make a wheel or depth bar adjustment while the engine is running.
13. Do not leave the tiller unattended with the engine running.
14. Do not walk in front of the tiller while the engine is running.
15. Check the fuel before starting the engine. Gasoline is an extremely flammable fuel. Do not fill gasoline tank indoors, while the engine is running, or while the engine is still hot. Replace gasoline cap securely, and wipe off any spilled gasoline before starting the engine as it may cause a fire or explosion.
16. Do not run the engine while indoors. Exhaust gases are deadly poisonous.
17. Be careful not to touch the muffler after the engine has been running. It is hot.
18. Do not change the engine governor settings or overspeed the engine. Excessive engine speeds are dangerous.
19. Before any maintenance work is performed or adjustments are made, remove the spark plug wire and ground it on the engine block for added safety.
20. Use caution when tilling near buildings and fences. Rotating tines can cause damage or injury.
21. Before attempting to remove rocks, bricks and other objects from tines, stop the engine and be sure the tines have stopped completely. Disconnect the spark plug wire and ground to prevent accidental starting.
22. Check the tine and engine mounting bolts at frequent intervals for proper tightness.
23. Keep all nuts, bolts and screws tight to be sure the equipment is in safe working condition.
24. Never store the equipment with gasoline in the tank inside of a building where fumes may reach an open flame or spark. Allow the engine to cool before storing in any enclosure.

ASSEMBLY INSTRUCTIONS

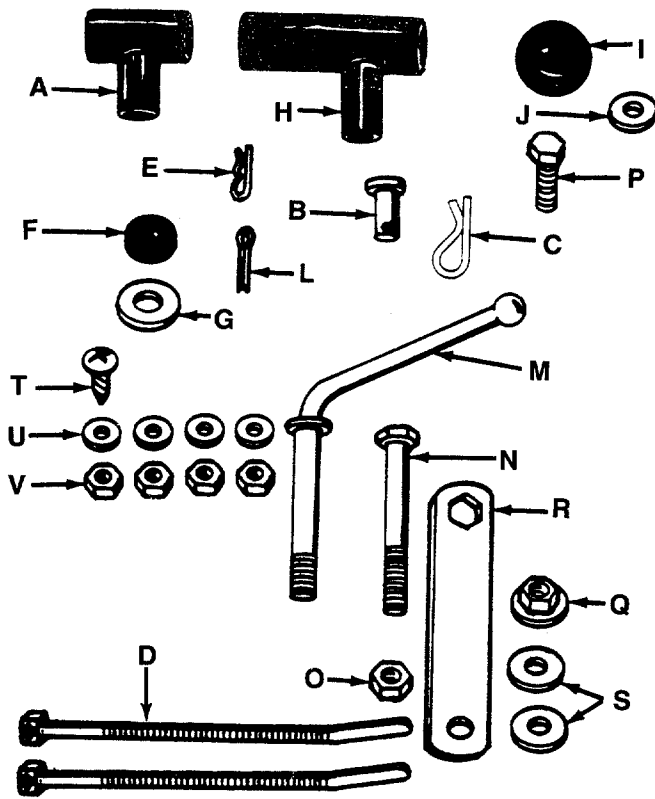

FIGURE 1.

NOTE: This unit is shipped **WITHOUT GASOLINE or OIL**. After assembly, see separate engine manual for proper fuel and engine oil recommendations.

NOTE: Left and right is determined from the operator's position, standing behind the tiller.

Contents of Hardware Pack: (See Figure 1)

- A (1) Small "T" Knob
- B (1) Clevis Pin
- C (1) Large Hairpin Clip
- D (2) Cable Ties
- E (1) Small Hairpin Clip
- F (1) Rubber Washer
- G (1) Flat Washer 3/8" I.D. x 1.25" O.D.
- H (1) Large "T" Knob
- I (1) Ball Knob
- J (1) Flat Washer 3/8" I.D. x 5/8" O.D.
- L (1) Cotter Pin
- M (1) Handle Adjustment Lock
- N (1) Hex Bolt 3/8-16 x 3-1/4" Long
- O (1) Hex Nut 3/8-16 Thread
- P (1) Hex Bolt 3/8-16 x 3/4" Long
- Q (1) Shoulder Nut
- R (1) Hex Nut Retainer Bracket
- S (2) Belleville Washers 3/8" I.D.
- T (1) Self-Tapping Screw 1/2" Long
- U (4) Belleville Washers 5/16" I.D.*
- V (4) Hex Nuts 5/16-18 Thread*

Loose Parts in Carton: (See Figure 2)

- (1) Handle Assembly
- (1) Control Rod
- (1) Handle Adjustment Rod
- (1) Depth Bar Assembly
- (2) Side Shields* (Not Shown)

*May be already assembled on your unit.

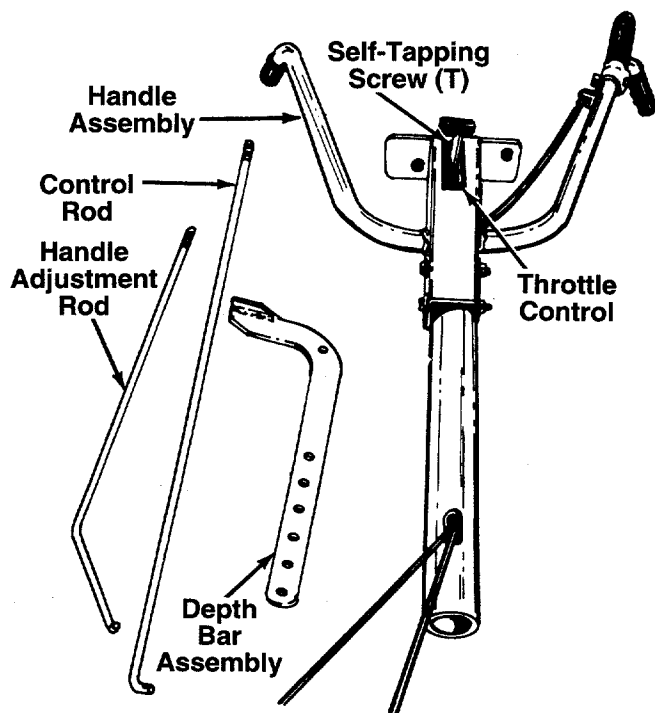

FIGURE 2.

1. Remove tiller, loose parts and hardware pack from carton. Make certain all parts and literature have been removed from the carton before the carton is discarded.
2. Extend all control cables and lay on the floor. Be careful not to bend or kink control cables.
3. Assemble the throttle control to the handle assembly as follows. See figure 2.
 - a. Pull the end of the throttle control cable which extends through the bottom of the handle to remove slack in the cable.
 - b. Snap the throttle control into the slot in the handle assembly.
 - c. Secure the top of the throttle control to the handle assembly with self-tapping screw (T).

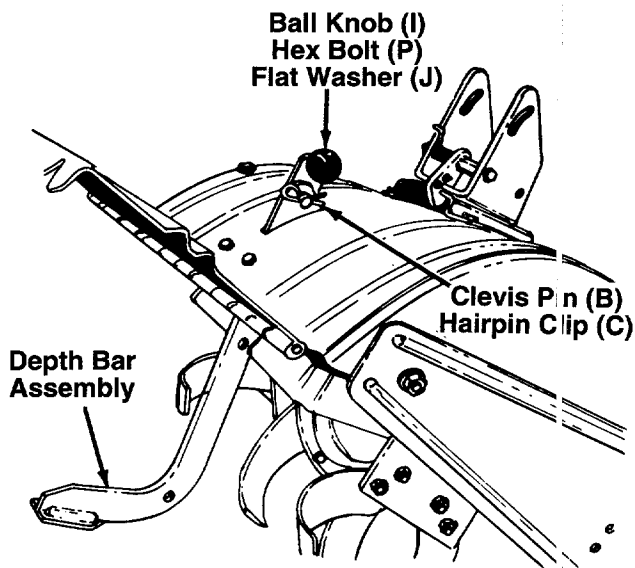

FIGURE 3.

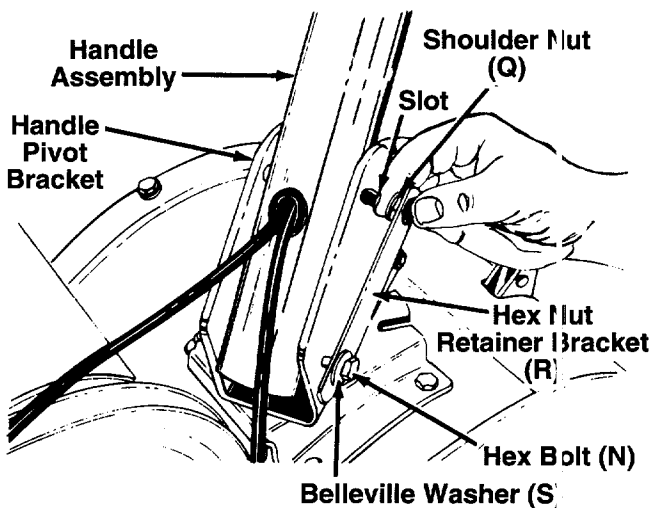

FIGURE 4.

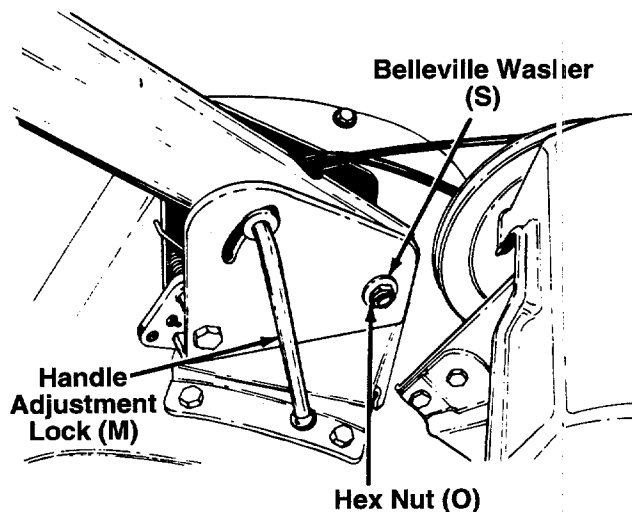

FIGURE 5.

4. Tip the tiller forward so it rests on front counterweight. See figure 3. ←
5. Raise the tine shield hinge flap assembly. Insert the depth bar assembly between the two shoulder bolts and up through the tine shield assembly as shown in figure 3.
6. Insert clevis pin (B) through the tine shield and depth bar assemblies. Secure with hairpin clip (C). See figure 3.
7. Insert hex bolt (P) into the upper hole of the depth bar assembly. Place flat washer (J) onto the hex bolt and thread ball knob (I) onto the hex bolt. See figure 3. Tighten securely.
8. Tip the tiller back down so it rests on the tines.
9. Place belleville washer (S) onto hex bolt (N) (crown side of washer goes against the bolt). Place hex nut retainer bracket (R) on hex bolt (N), using the round hole in retainer bracket.
10. Place handle assembly in position in the handle pivot bracket. Line up the holes in handle assembly with the holes (and slots) in the pivot bracket. ← See figure 4.
11. Insert hex bolt (with washer and hex nut retainer attached) through the bottom holes on the handle pivot bracket and handle assembly. Head of the hex bolt should be to the left hand side of the unit. See figure 4.
12. Place shoulder nut (Q) between hex nut retainer bracket and pivot bracket. See figure 4.
13. Secure bottom of handle by placing belleville washer (S) (cupped side against the pivot bracket) and hex nut (O) on hex bolt (N). Do not tighten at this time. See figure 5. ←
14. Insert handle adjustment lock (M) through handle pivot bracket and handle assembly. See figure 5. Thread end of handle adjustment crank into shoulder nut.
15. Pivot handle assembly into position desired. Tighten securely the bottom bolt and nut. Tighten the handle adjustment lock.

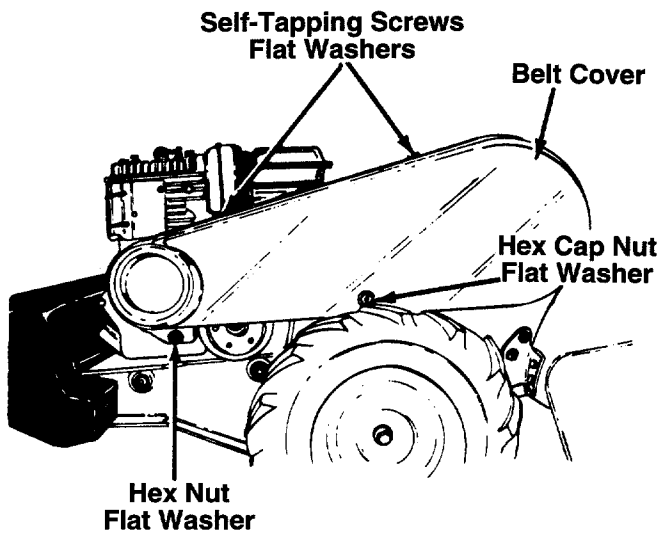

FIGURE 6.

16. Remove the belt cover from the left side of the tiller as follows. See figure 6.
- Remove two self-tapping screws and flat washers from the top of belt cover.
 - Remove the hex cap nut and flat washer from the middle of the belt cover.
 - Remove the hex nut and flat washer from the weld bolt at the bottom of the front of the belt cover.

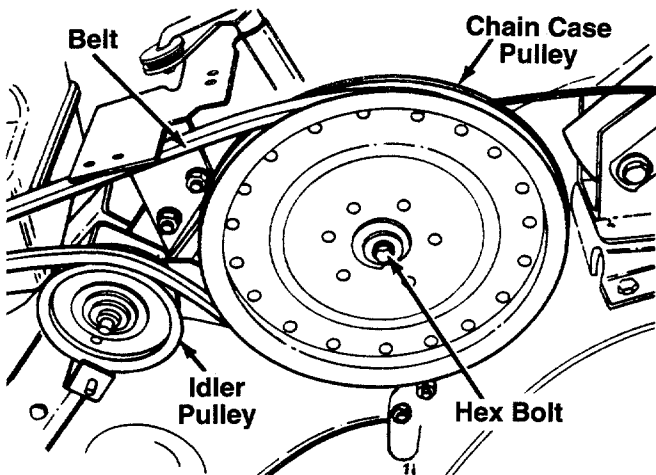

FIGURE 7.

17. The drive cable is the cable which has a spring on one end. Remove one hex nut from the end of the drive cable casing. Thread the other hex nut all the way up the threaded casing.
18. Remove the center bolt (and washers) from the chain case pulley (large pulley at the rear of the tiller). Remove the pulley from the splined shaft. See figure 7.

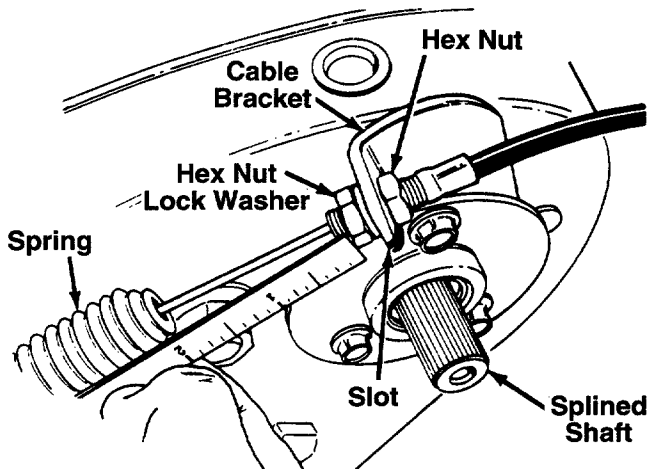

FIGURE 8.

19. There is a cable bracket which has a hole with a slot in it, located approximately 2 inches above the splined shaft. See figure 8. Pull the spring, the first nut and the lock washer all the way to the end of the cable. Slip the cable through the slot in the cable bracket, then slide the cable casing through the hole.
20. Thread the lock washer and hex nut back onto the cable casing so approximately 1/8" of threads show (only a couple threads). Thread the hex nut on the other side of the cable bracket against the bracket, and tighten securely. See figure 8.

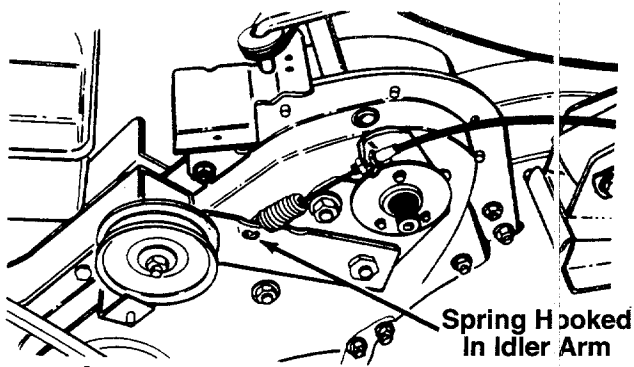

FIGURE 9.

21. Hook the spring into the hole in the idler arm bracket. See figure 9.
22. Slide the chain case pulley back onto the splined shaft. Secure with hardware removed in step 18. Place belt around the chain case pulley. Route the belt over top of the idler pulley. Refer to figure 7.

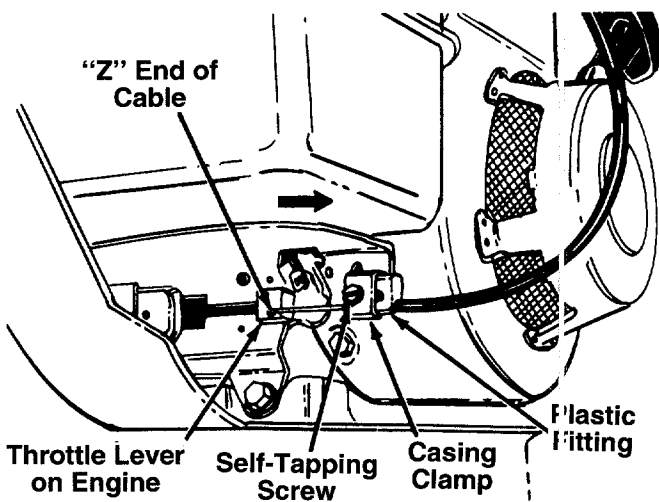

FIGURE 10.

23. Attach the throttle control cable to the throttle control lever on the engine as follows. See figure 10.

NOTE: It is helpful to use a light to illuminate the area beneath the fuel tank.

- a. Place the throttle control lever on the handle assembly in FAST position.
- b. Remove the casing clamp which is located under the gas tank on the right hand side of engine housing by removing the self-tapping screw.
- c. Hook the "Z" end of the throttle control cable into the hole in the control lever on the engine.
- d. Place the casing clamp over the plastic fitting on the throttle cable. Secure loosely to engine housing by inserting self-tapping screw through the casing clamp and the slot in the plastic fitting on the throttle control cable.
- e. Pull the throttle control cable so that the throttle lever on the engine is in the full open position (all the way toward the right side of the unit) as shown in figure 10. Tighten the self-tapping screw to secure the throttle control cable in this position.

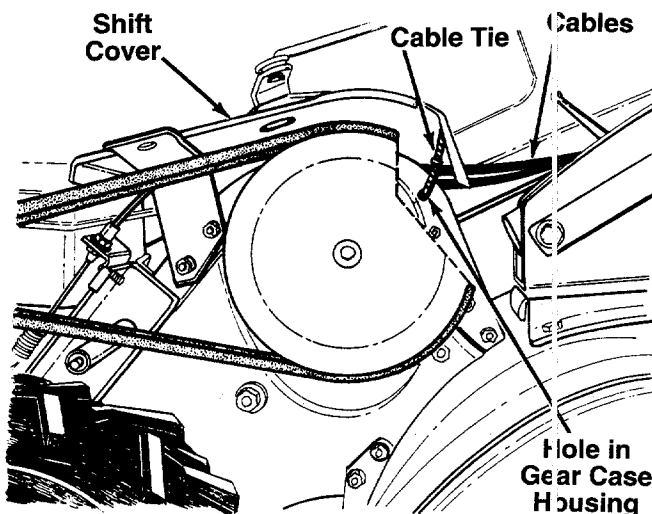

FIGURE 11.

24. Secure the drive cable and the throttle control cable to the top of the gear case housing (underneath the shift cover) using one of the cable ties (D) provided, keeping the cables away from the pulley. See figure 11. Cut off excess end of cable tie.
25. Replace the belt cover, and secure with hardware removed in step 16.

NOTE: Be careful not to overtighten the hex nut on the weld bolt at the lower front of belt cover.

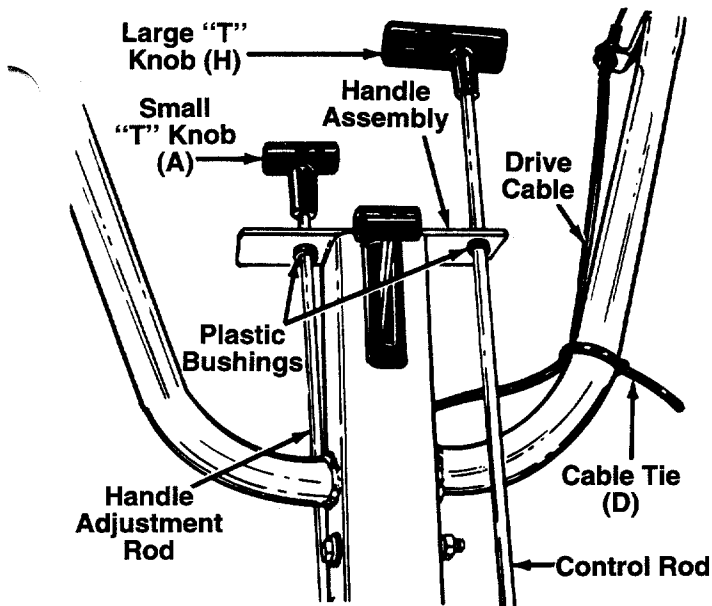

FIGURE 12.

26. Insert the threaded end of control rod up through the plastic bushing on the left side of handle assembly. See figure 12. Thread the large "T" knob (H) on the end of control rod.
27. Insert the threaded end of handle adjustment rod up through the plastic bushing on the right side of handle assembly. Thread the small "T" knob (A) on the end of handle adjustment rod.

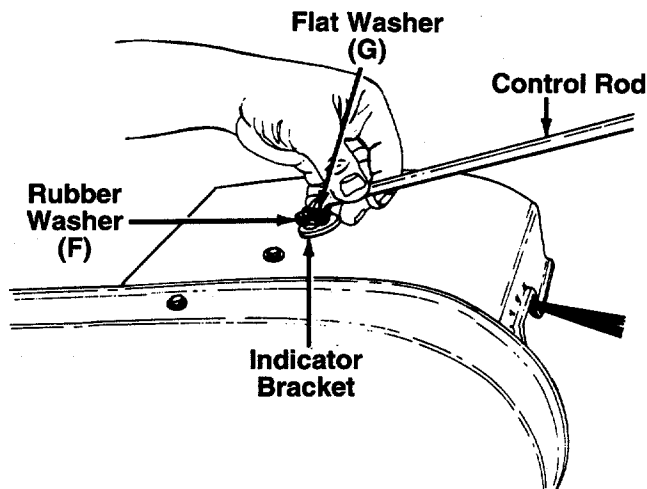

FIGURE 13.

28. Place flat washer (G), then rubber washer (F) over the hooked end of control rod. Insert end of control rod into the indicator bracket on top of the shift cover, and secure with hairpin clip (E). See figure 13.

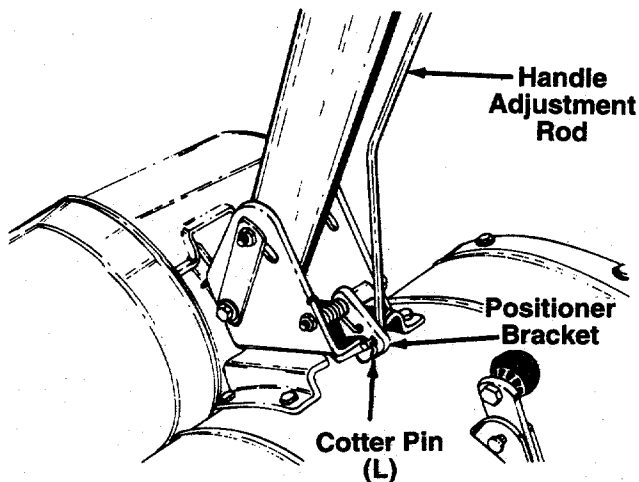

FIGURE 14.

29. Insert the hooked end of handle adjustment rod into the positioner bracket as shown in figure 14. Secure with cotter pin (L). Secure by bending ends of pin in opposite directions.
30. Secure drive cable to left handle using cable tie (D). Refer to figure 12. Cut off excess end of cable tie.

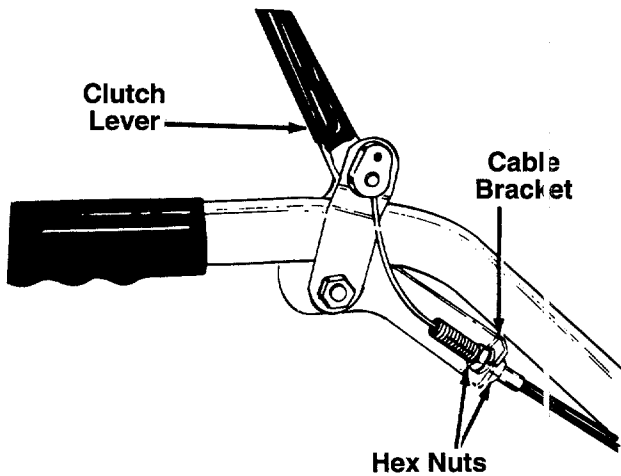

FIGURE 15.

31. Check the clutch adjustment as follows.

IMPORTANT: Service the engine with oil and gasoline before checking this adjustment. Refer to the separate engine manual packed with your tiller.

- a. Position the tiller so the front counterweight is against a solid object, such as a wall. With the gear selection lever in NEUTRAL, start the engine.
- b. Standing on the right side of the tiller, examine the belt (inside the belt cover). It should not be turning.

If the belt turns with the unit in neutral, adjust by moving the hex nut below the cable bracket **down** a few turns. See figure 15. Tighten the upper hex nut against the bracket.

- c. Now move the shift lever to FORWARD (Wheels Forward) position. Carefully engage the clutch by squeezing the clutch lever against the left handle. The wheels should spin.

If the wheels do not spin with the unit in forward, adjust by moving the hex nut which is above the cable bracket **up** a few turns. Tighten the bottom hex nut against the bracket.

Recheck both adjustments, and readjust as necessary.

NOTE: If you reach the point that additional adjustment is needed, remove the belt cover and move the hex nuts at the other end of the cable towards the end of the casing. Then readjust the hex nuts at the handle.

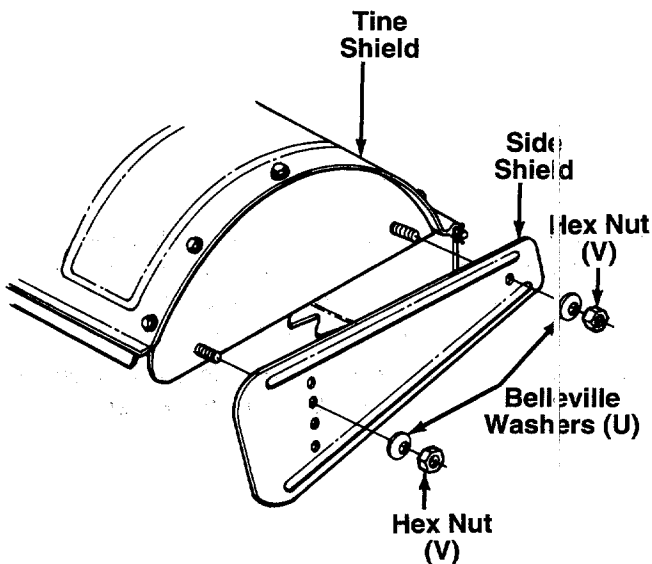

FIGURE 16.

32. Assemble the side shields to the tine shield using bellville washers (U) (cupped side against the side shields) and hex nuts (V) as shown in figure 16. The side shields will be adjusted up or down as the depth bar is adjusted. Refer to "How to Use Your Tiller" on page 10.

33. The tires on your unit may be over-inflated for shipping purposes. Reduce the tire pressure before operating the unit. Recommended operating tire pressure is approximately 12 p.s.i. (check sidewall of tire for tire manufacturer's recommended pressure).



WARNING: Maximum tire pressure under any circumstances is 30 p.s.i. Equal tire pressure should be maintained on both tires.

CONTROLS

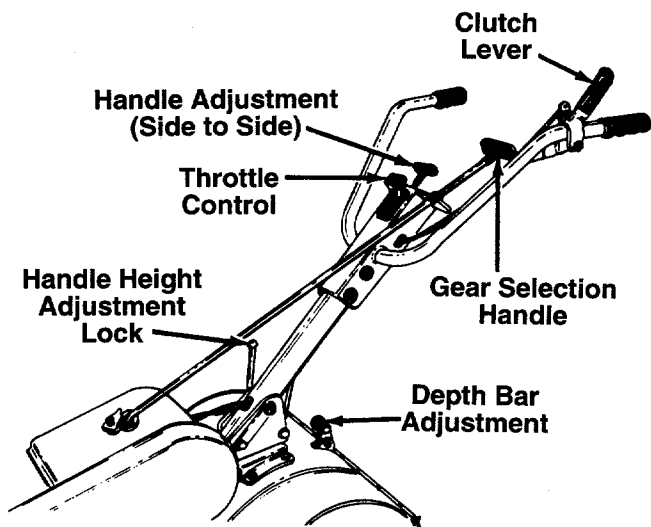

FIGURE 17.

THROTTLE CONTROL

The throttle control lever is located in the center of the handle assembly. It controls the engine speed and stops the engine. See figure 17.

GEAR SELECTION HANDLE

The gear selection handle is located to the left of the throttle control. It is used to select NEUTRAL, REVERSE, or one of the FORWARD modes (see below). Pull or push the handle so that the indicator on top of shift cover points to the operating mode desired. See figure 17.

NEUTRAL—Transmission is in neutral.

REVERSE—Reverse wheel drive.

FORWARD Modes:

Wheels Forward— Forward wheel drive only.

Tines Reverse— Forward wheel drive and reverse tine drive.

Tines Forward— Forward wheel and tine drive.



WARNING: Make certain unit is in NEUTRAL when starting the engine.

CLUTCH LEVER

The clutch lever is located on the left handle. See figure 17. Squeezing the clutch lever against the handle engages the wheel and tine drive mechanisms.

DEPTH BAR

The depth bar controls the tilling depth. Refer to “How to Use Your Tiller” section on page 10.

HANDLE ADJUSTMENT (See Figure 17)

The handle may be adjusted to be in line with the tiller, or swung to the left or right so the operator is not walking in the freshly tilled soil.

To adjust the handle position from side to side, pull the handle adjustment lever back, pivot the tiller handle to desired position and release the lever.

The handle may also be adjusted to the height desired. Loosen the handle height adjustment lock a few turns. Pivot handle up or down to desired position. Tighten lock.

OPERATION

NOTE: Engine is shipped without oil.



WARNING: Before operating the tiller, be certain to read “How to Use Your Tiller” on page 10. Use the reverse tine drive when tilling virgin ground, sod or hard soil. Use the forward tine drive when cultivating or tilling soft ground.

BEFORE STARTING

1. Service engine with oil as instructed in the separate engine manual packed with your unit.
2. Fill fuel tank with clean, fresh, lead-free, low-lead or regular grade leaded gasoline.
3. Be certain to check clutch adjustment as described in step 31 of Assembly Instructions.

TO START ENGINE



WARNING: BE SURE NO ONE IS STANDING IN FRONT OF THE TILLER WHILE THE ENGINE IS RUNNING OR BEING STARTED.

1. Place gear selection lever in NEUTRAL.
2. Place the throttle control lever in START position.
3. Move choke lever to CHOKE position. See figure 18.

NOTE: A warm engine may not require choking.

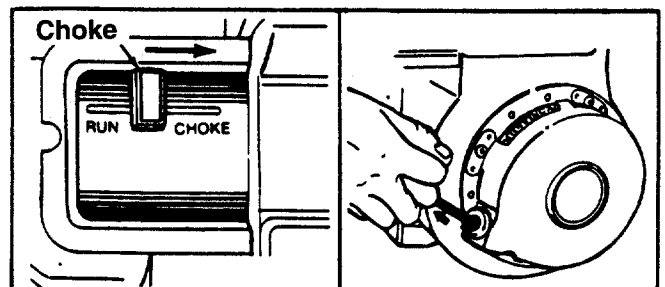

FIGURE 18.

- Stand at side of tiller. Grasp the starter handle and pull out slowly, until it pulls slightly harder. Let rope rewind slowly.
 - Pull starter handle rapidly. Do not allow handle to snap back. Allow it to rewind slowly while keeping a firm hold on the starter handle.
 - Repeat steps 4 and 5 until engine starts.
 - As engine warms up and begins to operate evenly, move choke lever gradually to RUN position. If engine falters, return to choke position, then slowly move to RUN position.
- Refer to engine manual for additional engine information.

TO STOP ENGINE

- Move throttle control to STOP position.
- Disconnect spark plug wire and ground to prevent accidentally starting while equipment is unattended.

NOTE: After the first ten hours of operation, recheck the clutch adjustment. Refer to step number 31 of the Assembly Instructions.

HOW TO USE YOUR TILLER



WARNING: When operating the tiller for the first time, use the depth bar setting that gives 1-1/2 inches of tilling depth (second hole from the top). Refer to figure 19.

Tilling depth is controlled by the depth bar which can be adjusted to five different settings. See figure 19. Adjust the side shields as shown in figure 20, as you adjust the depth bar. Be certain spark plug wire is disconnected and grounded against the engine.

- When using the tiller for the first time, use the second adjustment hole from the top (1-1/2" of tilling depth). See figure 19.

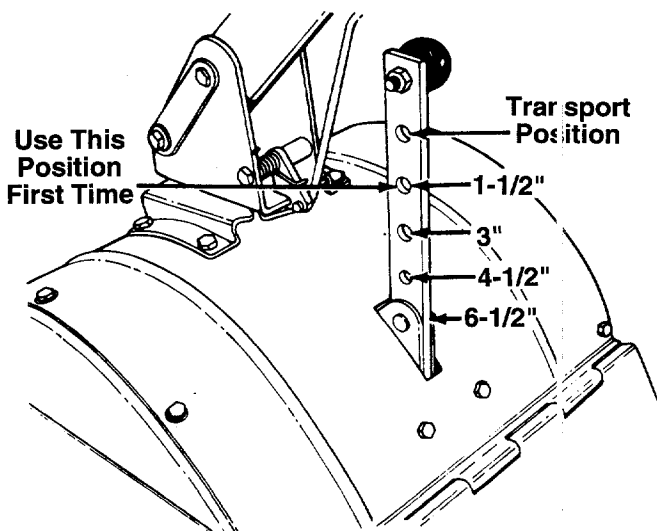

FIGURE 19.

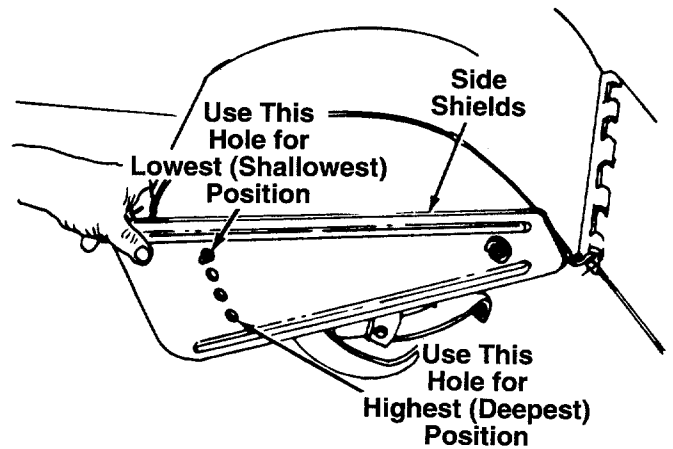

FIGURE 20.

- When breaking up sod and for shallow cultivation, use the setting which gives 1-1/2" of tilling depth (second hole from the top). Place the side shields in their lowest position. For further depth, raise the depth bar and side shields and make one or two more passes over the area.
- When tilling loose soil, depth bar may be raised to its highest position (use bottom adjustment hole) to give the deepest tilling depth. Raise the side shields to their highest position.
- To transport tiller, lower the depth bar (use top adjustment hole).

To adjust the depth bar, remove the clevis pin and hairpin clip. See figure 19. Move the depth bar to the desired setting.

To adjust the side shields, remove the hex nut and belleville washer from the front and loosen the rear nut. See figure 20. Pivot the side shield to the desired position. Replace hex nut and belleville washer. Tighten securely.

To operate the tiller:

- Select the depth bar setting.
- Start engine as instructed on page 9.
- Move gear selection handle to one of the forward modes or reverse. **Use the reverse tine drive when tilling virgin ground, sod or hard soil. Use the forward tine drive when cultivating or tilling soft ground.**

IMPORTANT: When using the forward tine drive, lower the depth bar (use a shallower tilling depth) to make certain the tines do not run across the ground.



WARNING: Do not move the gear selection handle with the wheels or tines engaged. Make certain the unit is stopped completely before changing the gear selection.

4. Squeeze the clutch lever against the handle to engage the wheels and tines.

NOTE: *Make certain the gear selection indicator is correctly positioned before engaging the clutch handle. If it is between gears, the engine will stall.*

To transport tiller, **do not** engage the tines. Select the wheel drive only.



WARNING: Do not push down on the handles so that the wheels are lifted off the ground while using the reverse tine drive, or the tiller could move backward and cause personal injury.

For best results, it is recommended the garden be tilled twice (lengthwise, then widthwise) to pulverize the soil.

ADJUSTMENTS

HANDLE ADJUSTMENT

The handle may be adjusted to be in line with the tiller, or swung to the left or right. The handle height may also be adjusted. Refer to the Control section for details of handle adjustment.

BELT TENSION ADJUSTMENT

Periodic adjustment of the belt tension may be required due to normal stretch and wear on the belt. Adjustment is needed if the tines or wheels seem to hesitate while turning, but the engine maintains the same speed.

To adjust to the tension on the belt, refer to clutch adjustment information in step number 31 of the Assembly Instructions.

CARBURETOR ADJUSTMENT



WARNING: If any adjustments are made to the engine while the engine is running, (e.g. carburetor), disengage all clutches and tines. Keep clear of all moving parts. Be careful of heated surfaces and muffler.

Never make unnecessary adjustments. The factory settings are correct for most applications. If adjustments are needed, refer to the separate engine manual packed with your tiller.

LUBRICATION

Transmission—The transmission is pre-lubricated and sealed at the factory. It requires no checking unless the transmission is disassembled. To fill with grease, lay the right half of the transmission on its side. Add 27 ounces of Benalene #372-0 grease. Assemble the left half to it. This grease can be obtained at your nearest authorized dealer. Order part number 737-0223.

Clutch Lever—Lubricate the pivot point on the clutch lever and the cable at least once a season with light oil. The control must operate freely in both directions.

Pivot Points—Lubricate all pivot points and linkages at least once a season with light oil.

MAINTENANCE



WARNING: Disconnect the spark plug wire and ground it against the engine before performing any repairs or maintenance.

ENGINE

Refer to the separate engine manual for engine maintenance instructions.

Maintain **engine oil** as instructed in the separate engine manual packed with your unit. Read and follow instructions carefully.

Service **air cleaner** every ten hours under normal conditions. Clean every hour under extremely dusty conditions. Poor engine performance and flooding usually indicates that the air cleaner should be serviced. To service the air cleaner, refer to the separate engine manual packed with your unit.

IMPORTANT: Never run your engine without air cleaner completely assembled.

The **spark plug** should be cleaned and the gap reset every 25 hours of engine operation. Spark plug replacement is recommended at the start of each tiller season; check engine manual for correct plug type and gap specification.

Clean the engine regularly with a cloth or brush. Keep the cooling system (blower housing area) clean to permit proper air circulation which is essential to engine performance and life. Be certain to remove all dirt and combustible debris from muffler area.

CLEANING THE TINE AREA

Clean the underside of the tine shield after each use. The dirt washes off the tines easier if washed off immediately instead of after it dries.

TIRES

Recommended operating tire pressure is approximately 12 p.s.i. (check sidewall of tire for tire manufacturer's recommended pressure). Maximum tire pressure under any circumstances is 30 p.s.i. Equal tire pressure should be maintained on both tires.

When installing a tire to the rim, be certain rim is clean and free of rust. Lubricate both the tire and rim generously. Never inflate to over 30 p.s.i. to seat beads.



WARNING: Excessive pressure (over 30 p.s.i.) when seating beads may cause tire/rim assembly to burst with force sufficient to cause serious injury.

BELT REPLACEMENT



CAUTION: Do not use an off-the-shelf belt.

Your tiller has been engineered with a belt made of special material (Kevlar Tensile) for longer life and better performance. It should not be replaced with an off-the-shelf belt.

If belt replacement is required, order belt or belts by part number from your nearest authorized dealer:
Part No. 754-0267—"V" Belt

1. Disconnect and ground the spark plug wire against the engine.
2. Remove the belt cover from the left side of the tiller as follows. Refer to figure 6.
 - a. Remove two self-tapping screws and flat washers from the top of belt cover.
 - b. Remove the hex cap nut and flat washer from the side of the belt cover. Remove the hex nut and flat washer at the bottom of the front of the cover.
3. Remove the hex bolt (belt keeper) located beneath the engine pulley. See figure 21.
4. Remove belt. Reassemble new belt, following instructions in reverse order.

NOTE: Upon reassembly, make certain the belt is routed over the idler pulley and inside of belt keepers by engine pulley. See figure 21.

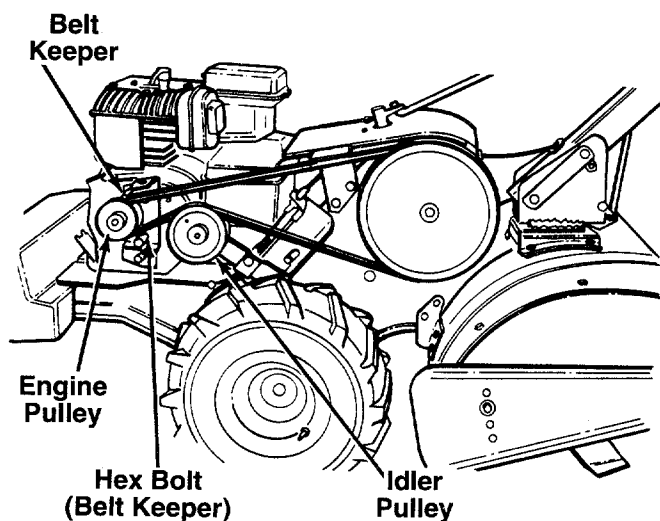

FIGURE 21.

OFF-SEASON STORAGE

If the tiller will not be used for a period longer than 30 days, the following steps should be taken to prepare the tiller for storage.

1. Clean the exterior of engine and the entire tiller thoroughly. Lubricate the tiller as described in the lubrication instructions.
2. Refer to the engine manual for correct engine storage instructions.
3. Wipe tines with oiled rag to prevent rust.
4. Store tiller in a clean, dry area. Do not store next to corrosive materials, such as fertilizer.

NOTE: When storing any type of power equipment in an unventilated or metal storage shed, care should be taken to rustproof the equipment. Using a light oil or silicone, coat the equipment, especially any springs, bearings and cables.

TROUBLE SHOOTING GUIDE

Trouble	Possible Cause(s)	Corrective Action
Engine fails to start	<ol style="list-style-type: none"> 1. Fuel tank empty, or stale fuel. 2. Throttle control lever not in starting position. 3. Spark plug wire disconnected. 4. Faulty spark plug. 5. Engine flooded. 	<ol style="list-style-type: none"> 1. Fill tank with clean, fresh gasoline. 2. Move throttle lever to START position. 3. Connect wire to spark plug. 4. Clean, adjust gap or replace. 5. Remove spark plug, dry the plug, and crank engine with plug removed and throttle in off position. Replace spark plug, connect wire and resume starting procedures.
Engine runs erratic	<ol style="list-style-type: none"> 1. Unit running on CHOKE. 2. Spark plug wire loose. 3. Stale fuel. 4. Vent in gas cap plugged. 5. Water or dirt in fuel system. 6. Dirty air cleaner. 7. Carburetor out of adjustment. 	<ol style="list-style-type: none"> 1. Move choke lever to OFF position. 2. Connect and tighten spark plug wire. 3. Fill tank with clean, fresh gasoline. 4. Clear vent. 5. Drain fuel tank. Refill with fresh fuel. 6. Clean air cleaner as instructed in separate engine manual. 7. Adjust carburetor as instructed in separate engine manual.
Engine overheats	<ol style="list-style-type: none"> 1. Engine oil level low. 2. Air flow restricted. 3. Carburetor not adjusted properly. 	<ol style="list-style-type: none"> 1. Fill crankcase with proper oil. 2. Remove blower housing and clean as instructed in separate engine manual. 3. Adjust carburetor as instructed in separate engine manual.
Tines do not engage	<ol style="list-style-type: none"> 1. Foreign object lodged in tines. 2. Tine clevis pin(s) missing. 3. Control cable not adjusted properly. 4. Belt worn and/or stretched. 	<ol style="list-style-type: none"> 1. Dislodge foreign object. 2. Replace tine clevis pin(s). 3. Adjust control cable (see assembly instructions). 4. Replace belt.
Wheels do not engage	<ol style="list-style-type: none"> 1. Control cable not adjusted properly. 2. Belt worn and/or stretched. 	<ol style="list-style-type: none"> 1. Adjust control cable (see assembly instructions). 2. Replace belt.

NOTE: For repairs beyond the minor adjustments listed above, please contact your local service dealer.

Model 430

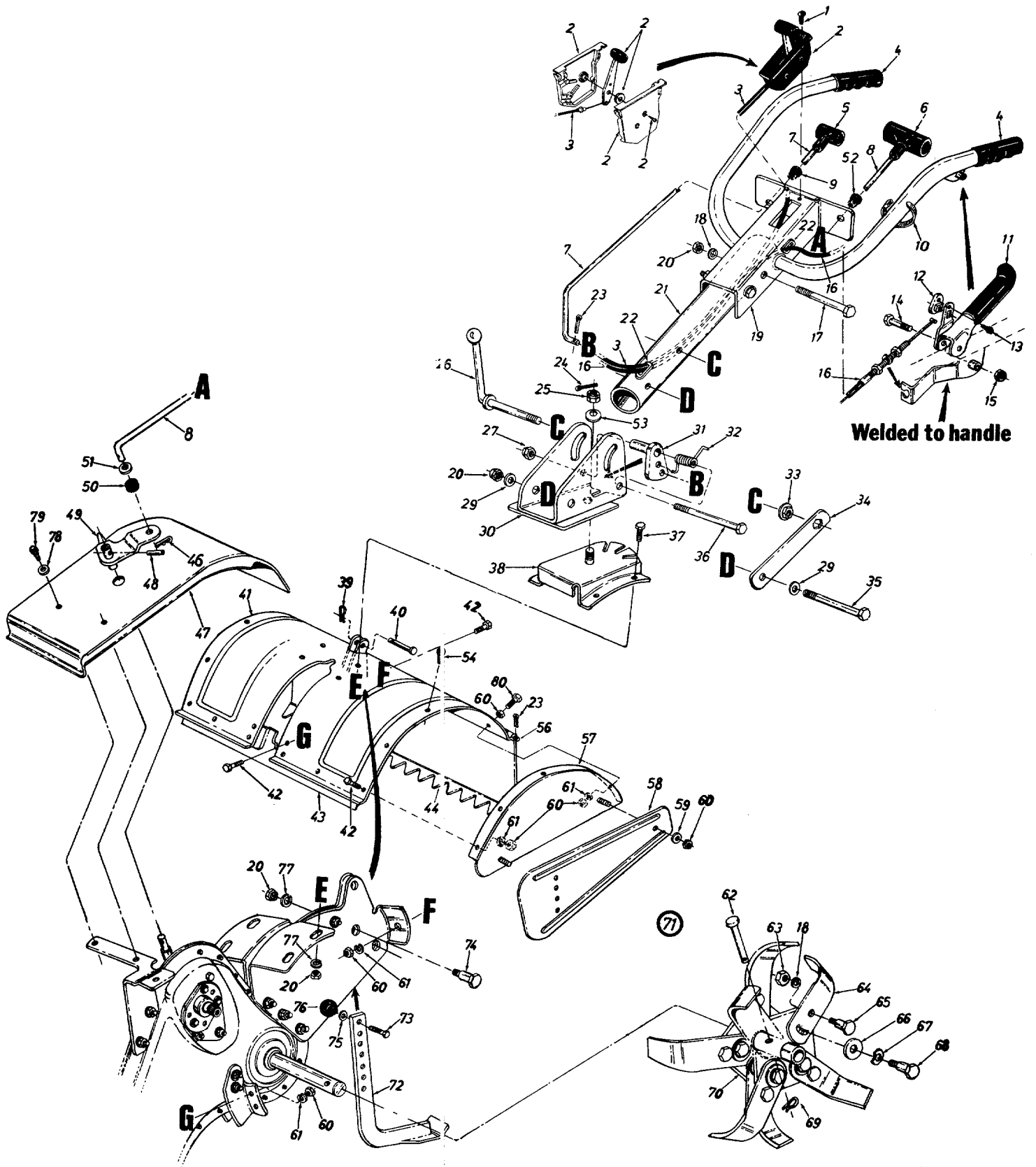

Model 430

PARTS LIST FOR MODEL 430 REAR TINE TILLER

REF. NO.	PART NO.	CODE	DESCRIPTION	REF. NO.	PART NO.	CODE	DESCRIPTION
1	710-0779A		Truss Mach. AB-Tap. Scr. #10 x .50" Lg.	39	714-0149B		Intern. Cotter Pin
2	831-0823A		Throttle Control Box Ass'y.	40	711-0415		Clevis Pin .375" Dia.
3	746-0513		Throttle Control Wire	41	784-0156		Tine Shield 18"
4	720-0180		Handle Grip	42	710-0118		Hex Bolt 5/16-18 x .75" Lg.*
5	720-0210A		Small "T" Knob	43	784-0210		Bracket Reinforcement—18"
6	720-0209		Large "T" Knob	44	14979		Tine Shield Hinge Flap
7	747-0666		Clutch Rod	46	714-0104		Intern. Cotter Pin 5/16" Dia.
8	747-0664		Control Rod 37" Lg.	47	784-0208A		Shift Cover
9	735-0228		Snap On Bushing 3/8" Dia.	48	715-0120		Spring Roll Pin 3/16" Dia.
10	725-0157		Cable Tie-Self Clinching	49	784-0173		Shifting Crank Ass'y.
11	784-0202B		Clutch Grip Ass'y.—L.H.	50	735-0127		Rubber Washer .33" I.D.
12	746-0605		Barrel Cable Hold Down	51	736-0133		Fl-Wash. .4" I.D. x 1.25" O.D.
13	710-0919		Hex B-Tap Scr. #10 x .44" Lg.	52	735-0227		Snap On Bushing 1/2" Dia.
14	710-0331		Hex Bolt 3/8-24 x 2.25" Lg.*	53	736-0317		Bell-Wash. .63" I.D. x 1.25"
15	712-0262		Hex Jam L-Nut 3/8-24 Thd.	54	710-0607		Hex Wash. Tap Scr.
16	746-0908		Clutch Control Cable 46" Lg.	56	747-0432		Tiller Flap Rod
17	710-0194		Hex Bolt 3/8-16 x 3.00" Lg.*	57	784-0179		End Cover Ass'y.
18	736-0217		L-Wash. 3/8" I.D.—H.D.	58	15390		Side Shield
19	784-0185B	N	Handle Ass'y.	59	736-0242		Bell-Wash. .345" I.D. x .88"
20	712-0798		Hex Nut 3/8-16 Thd.*	60	712-0267		Hex Nut 5/16-18 Thd.*
21	784-0189		Handle Tubing Ass'y.	61	736-0119		L-Wash. 5/16" I.D.*
22	735-0226		Rubber Grommet .66" I.D.	62	711-0415		Clevis Pin .375" Dia.
23	714-0507		Cotter Pin 3/32" Dia. x .75" Lg.*	63	712-0241		Hex Nut 3/8-24 Thd.*
24	714-3021		Cotter Pin 3/32" Dia. x 1.25" Lg.*	64	742-0305		13" Dia. Articulating Tine
25	712-0386A		Hex Slotted Nut 5/8-18 Thd.	65	738-0689		Shld. Bolt 1/2" Dia. x .175
26	784-0190		Handle Adj. Crank	66	736-0208		Fl-Wash. .51" I.D. x 1.50"
27	712-0375		Hex Cent. L-Nut 3/8-16 Thd.	67	736-0255		Bell-Wash. .515" I.D. x 1.14"
29	736-0105		Bell-Wash. .4" I.D. x .87" O.D.	68	738-0688		Shld. Bolt 1/2" Dia. x .320
30	784-0182		Handle Pivot Bracket	69	714-0149B		Intern. Cotter Pin
31	784-0183		Positioner Crank Ass'y.	70	784-0160		Tine Adapter Ass'y. 18"
32	732-0493		Spring Handle Adj. (Torsion)	71	784-0205		Tine Ass'y. Comp. 18"
33	712-0379		Hex Flange Nut 3/8-24 Thd.	72	14992		Depth Bar Ass'y.
34	784-0191		Bracket Hex Nut Retainer	73	710-0216		Hex Bolt 3/8-16 x .75" Lg.*
35	710-0644		Hex Bolt 3/8-16 x 3.25" Lg.*	74	738-0148		Shld. Bolt 1/2" I.D. x .62" Lg.
36	710-0521		Hex Bolt 3/8-16 x 3.00" Lg.— Gr. 8	75	736-0117		Fl-Wash. 3/8" I.D. x 5/8" O.D.
37	710-0253		Hex Bolt 3/8-16 x 1" Lg.*	76	720-0165		Ball Knob
38	784-0181A		Handle Positioner Brkt. Ass'y.	77	736-0169		L-Wash. 3/8" I.D.*
				78	736-0463		Fl-Wash. .281" I.D. x .62"
				79	710-0599		Hex Wash. Self-Tap Scr. 1/4-20 x .50" Lg.
				80	710-0528		Hex Bolt 5/16-18 x 11/4" Lg.*

*For faster service obtain standard nuts, bolts and washers locally. If these items cannot be obtained locally, order by part number and size as shown on parts list.

CODE: N notates a new part (not previously existing).

COLOR: A three digit number is the color code. Specify color code if color or finish is important when ordering parts. [i.e., (part no.)-638 for Red Finish]

 **NOTE**
Specifications subject to change without notice or obligation.

Color Codes

436—Radiant Yellow	638—Red
460—Green Flake	640—Green
483—Charcoal Gray	646—CM Blue
498—Yellow	650—Red Metallic
499—Beige	657—Teal
629—Silver Flake	663—Dark Teal
637—Black	

Model 430

IMPORTANT: Use only Original Equipment Manufacturer (O.E.M.) V-belts when replacing belts. They are of special construction (type of cord, cord location, length, etc.). Use of V-belts other than O.E.M. belts generally will provide only temporary service. For best results, use only factory approved parts.

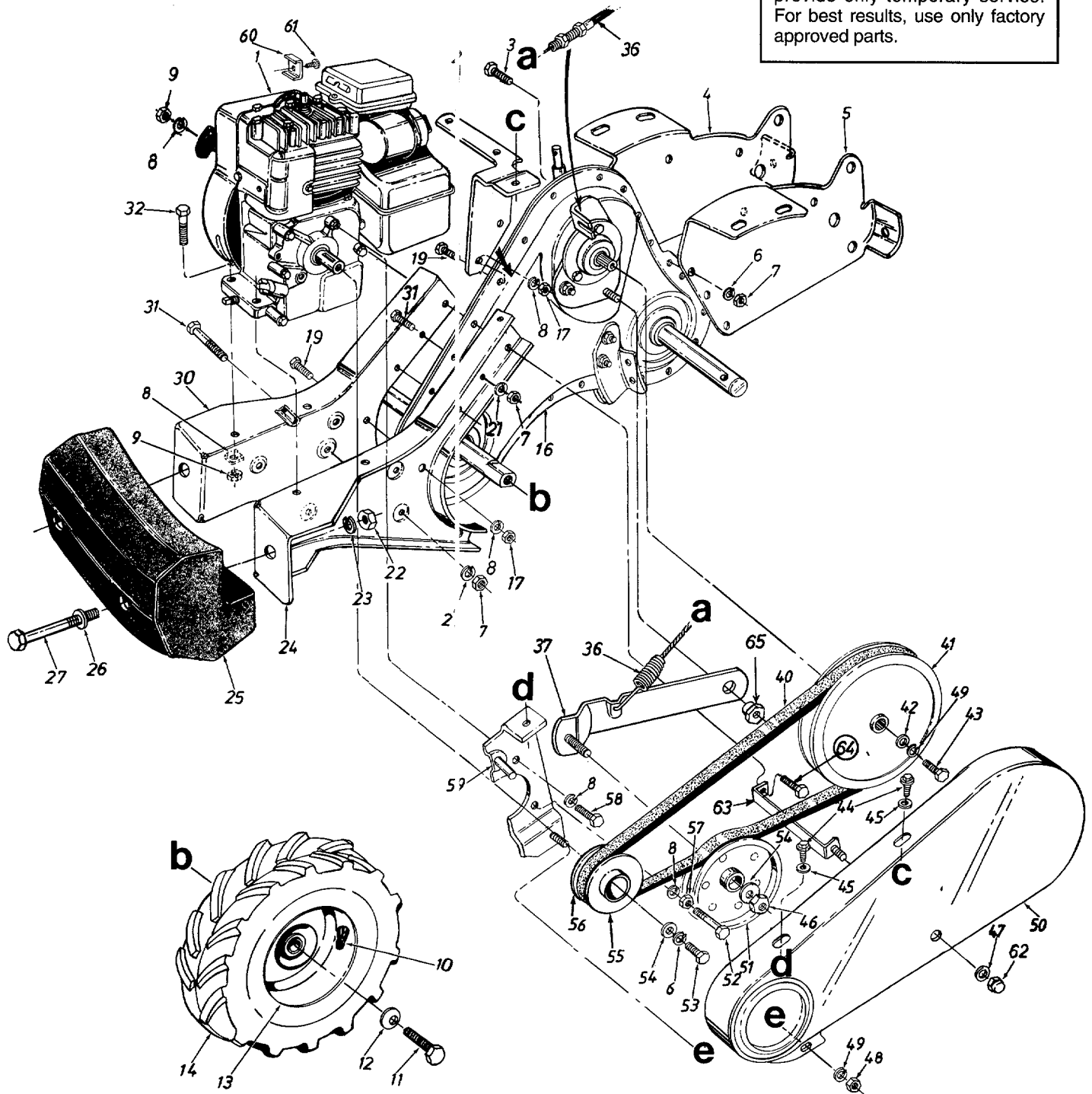

Model 430

PARTS LIST FOR MODEL 430 REAR TINE TILLER

REF. NO.	PART NO.	CODE	DESCRIPTION	REF. NO.	PART NO.	CODE	DESCRIPTION
1	—		Engine	36	746-0908	N	Clutch Control Cable 46" Lg.
2	784-0199A		Belt Cover Mounting Brkt.	37	686-0026	N	Idler Bracket Ass'y.
3	710-0253		Hex Bolt 3/8-16 x 1.00" Lg.*	40	754-0267		"V"-Belt
4	784-0178		Tine Shield Mtg. Brkt.—R.H.	41	756-0634	N	FI-Pulley 8" O.D.
5	784-0177		Tine Shield Mtg. Brkt.—L.H.	42	736-0176		FI-Wash. 1/4" I.D. x .93" O.D.
6	736-0169		L-Wash. 3/8" I.D.*	43	710-0412		Hex Bolt 1/4-28 x .75" Lg.
7	712-0798		Hex Nut 3/8-16 Thd.*	44	710-0599		Hex Wash. Hd. S-Tap Scr. 1/4-20 x .50" Lg.
8	736-0119		L-Wash. 5/16" I.D.*				FI-Wash. .281" I.D. x .625"
9	712-0267		Hex Nut 5/16-18" Thd.*	45	736-0463		Hex Cent. L-Nut 3/8-24 Thd.
10	734-0255		Air Valve	46	712-0262		FI-Wash. .266" I.D. x .625" O.D.
11	710-0237		Hex Bolt 5/16-24 x .62" Lg.*	47	736-3020		Hex Nut 1/4-20 Thd.*
12	736-0242		Bell-Wash. .345" I.D. x .88"	48	712-0287		L-Wash. 1/4" I.D.*
13	734-1376		Wheel Rim Ass'y. Only	49	736-0329		Belt Cover
14	734-1377		L.H. Wheel Ass'y. Comp.	50	784-0158		FI-Idler w/Flanges 3.75" O.D.
	734-1378		R.H. Wheel Ass'y. Comp.	51	756-0405		Hex Bolt 5/16-24 x 1.75**
	734-1154		Tire Only 13 x 5.0	52	710-0409		Hex Bolt 3/8-24 x 1.00" Lg.*
16	784-0150		Transmission Comp.	53	710-0152		FI-Wash. 3/8" I.D. x 1.00"
17	712-0267		Hex Nut 5/16-18 Thd.*	54	736-0258		Outer Engine Pulley Half
19	710-0118		Hex Bolt 5/16-18 x .75" Lg.*	55	756-0971		Inner Engine Pulley Half
21	736-0217		L-Wash. 3/8" I.D.—H.D.	56	756-0972		Hex Nut 5/16-24 Thd.*
22	712-0206		Hex Nut 1/2-13 Thd.*	57	712-0123		Hex Bolt 5/16-24 x .62" Lg.*
23	736-0921		L-Wash. 1/2" I.D.*	58	710-0237		Belt Keeper Ass'y.
24	784-0155		Engine Mounting Rail—R.H.	59	784-0197		Casing Clamp
25	723-0381		#40 Counter Weight	60	751-0360A		Hex Sems Scr. #10-32 x .62"
26	736-0326		FI-Wash. .510" I.D. x 1.0"	61	710-0899A		Hex Cap Nut 1/4-28 Thd.
27	710-0382		Hex Bolt 1/2-13 x 5.00" Lg.*	62	712-0392		Belt Cover Brkt. Ass'y.
30	784-0154		Engine Mounting Rail—L.H.	63	686-0027	N	Hex Bolt 5/16-18 x 1" Lg. (Gr. 5)
31	710-0216		Hex Bolt 3/8-16 x .75" Lg.*	64	710-0376		Shld. Nut
32	710-0442		Hex Bolt 5/16-18 x 1.50**	65	738-0876	N	

*For faster service obtain standard nuts, bolts and washers locally.
If these items cannot be obtained locally, order by part number and size as shown on parts list.

Model 430

TRANSMISSION 784-0150

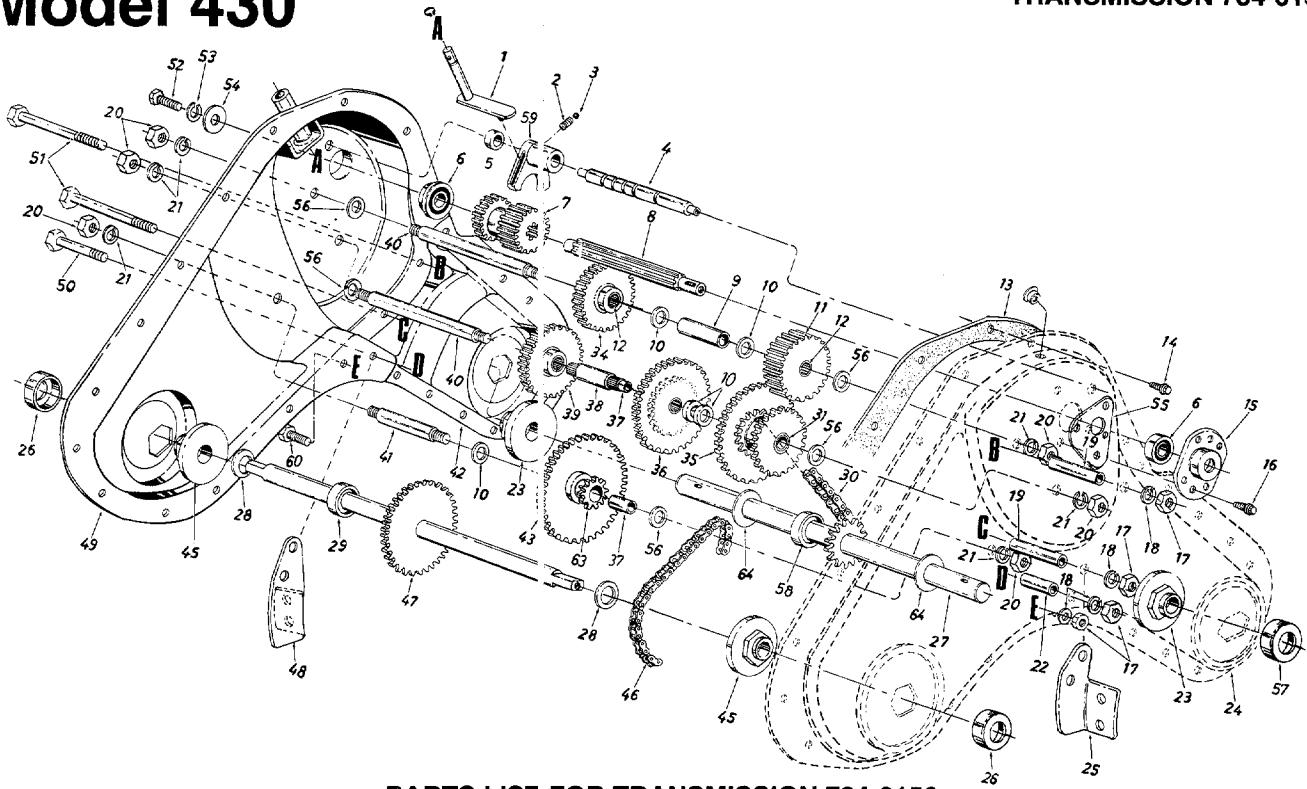

PARTS LIST FOR TRANSMISSION 784-0150

REF. NO.	PART NO.	CODE	DESCRIPTION	REF. NO.	PART NO.	CODE	DESCRIPTION
1	784-0171A		Shifting Bracket Ass'y.	34	717-0854		Spur Gear 30T 12/16" I.D.
2	732-0496		Compression Spring .50" Lg.	35	717-0874		30/44T Gear Ass'y. Comp.
3	741-0862		Ball Detent .250" Dia.	36	717-0863		Spur Gear 44T
4	738-0645		Detent Shaft 1/2" Dia.	37	741-0181		Sleeve Bearing
5	750-0664		Spacer .505" I.D. x .88" O.D.	38	717-0835		Gear Hub 3/4" I.D. x 3" Lg.
6	741-0155		Ball Brg. .62" I.D. x 1.38"	39	717-0855		Spur Gear 30T 1.0" I.D. x 1/2" W
7	717-0851		Spur Gear 16T (Input)	40	738-0647		Jack Shaft 5/8" Dia. x 5"
8	717-0852		Input Spline Shaft 7/8"	41	738-0648		Jack Shaft 5/8" Dia. x 2.38"
9	750-0651		Spacer .657" I.D. x 2.85" Lg.	42	784-0215		Trans. Housing Ass'y.—R.H.
10	736-0187		Fl-Wash. .640" I.D. x 1.1/4"	43	717-0858		Spur Gear 55T
11	717-0857		Spur Gear 30T 7/8" I.D.	44	741-0421		Wheel Brg. .752" x 2.5"
12	741-0478		Needle Bearing 5/8" I.D.	45	713-0367		#420 Chain 1/2 Pitch x 50 Links—Endless
13	721-0211		Gasket—Trans. Hsg.	46			Wheel Shaft Ass'y. 15.6"
14	710-0599		Hex S-Tap Scr. 1/4-20 x .5"	47	784-0170		Bracket Gear Case—R.H.
15	784-0211		1-3/8" Dia. Bearing Housing	48	784-0192		R.H. Housing Ass'y.
16	710-0642		Hex TT-Tap Scr. 1/4-20 x .75"	49	784-0195		Hex Bolt 5/16-18 x 2"
17	712-0267		Hex Nut 5/16-18 Thd.*	50	710-0116		Hex Bolt 5/16-18 x 2.5"
18	736-0119		L-Wash. 5/16" I.D.*	51	710-0378		Hex Bolt 1/4-20 x .62" Lg.
19	750-0662		Spacer 1.56" Lg.	52	710-0513		L-Wash. 3/8" I.D.*
20	712-0378		Hex Nut 7/16-20 Thd.	53	736-0169		Fl-Wash. 1/4" I.D. x .93" O.D.
21	736-0407		Bell-Wash. .45" I.D. x 1.0"	54	736-0176		Gear Positioner Bracket
22	750-0661		Spacer 1.015" Lg.	55	786-0065	N	Fl-Wash. 7/16" I.D. x 1-3/8"
23	741-0420		Tine Shaft Brg. 1.002 x 2.50	56	736-0406		Dust Cover Ass'y. 1" Shaft
24	784-0214		Trans. Housing Ass'y.—L.H.	57	784-0167		Spacer 1" I.D. x 2" O.D.
25	784-0193		Bracket Gear Case—L.H.	58	750-0570		Shifting Fork
26	784-0166		Dust Cover Ass'y.—Shaft	59	717-0853		Hex Bolt 5/16-18 x .75" Lg.*
27	784-0168		Tine Shaft Ass'y. 1" O.D.	60	710-0118		10T Sprocket Ass'y.
28	736-0351		Fl-Wash. .76" I.D. x 1.5" O.D.	61	784-0162		Thrust Wash. 1.03" I.D. x 1.62" O.D.
29	750-0671		Spacer .75" I.D. x .50" Lg.	62	736-0163		10 oz. Tube Benalene #372-0 Grease (27 oz. Req'd.)
30	713-0226		Chain #50 5/8 Pitch x 52: Links—Endless	63			
31	741-0488		Needle Bearing 5/8" I.D.	64			
32	716-0865		Snap Ring		737-0223		
33	726-0277		Taper Cap Plug				



NOTE: The engine is not under warranty by the tiller manufacturer. . . If repairs or service is needed on the engine, please contact your nearest authorized engine service outlet. Check the "Yellow Pages" of your telephone book under "Engines-Gasoline."



For Replacement Parts, Contact:
SERVICE DEPARTMENT • P.O. BOX 368022 • CLEVELAND, OHIO 44136-9722